

TIRE HANDLERS/MANIPULATORS

W-Series for Forklift Trucks



WBM Tire Handlers are designed to safely and efficiently handle OTR tires and rim assemblies on large mobile equipment.

Also available in capacities from 3,000lb / 1,365Kg to 40,000lb / 18,180Kg for forklift trucks.

FEATURES & BENEFITS

- "Clear path" low profile body and grip arm design allows the operator maximum visibility and versatility to reach wheel rim components on inside dual position and maintain clearance to the machine even during vertical dismounts
- Parallelogram link grip arms for maximum operation range – allows for handling rim components and tires or wheel assemblies
- Rim handling pads allow heavy rim components to be handled with ease and safety
- Finger tip / joystick proportional controls for effortless and precise handling of tires and rim components
- Bead Breaker / Fall arrest arms for ultimate operational safety for the tire technician

Continued on next page >>

GRIP ARM DESIGN

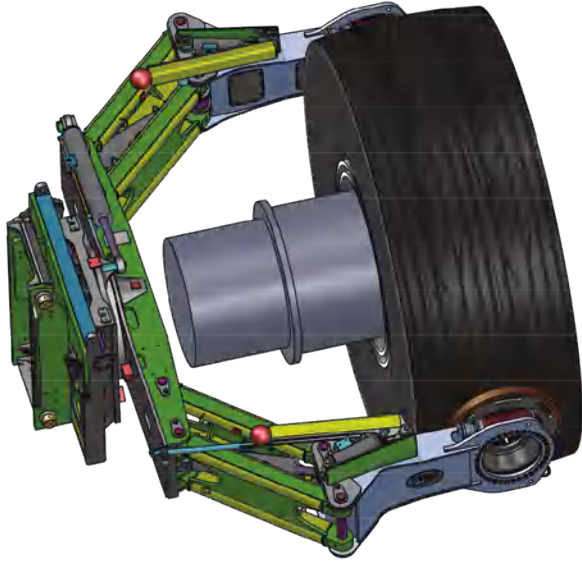

“CLEAR PATH” LOW PROFILE GRIP ARM DESIGN

Available across the entire product line , the WBM “Clear Path” low profile grip arm design allows the operator to reach in to grab inside rear dual flange ring on ultra class wide base trucks – the grip pad teeth are always the narrowest point .

Parallel low profile arm design allows grip pads to close enough to pick up rim hardware and components and wide enough for the largest diameter tires on the market and still maintain clearance to the machine, including dual hub / wheel rims and fuel or hydraulic oil tanks.

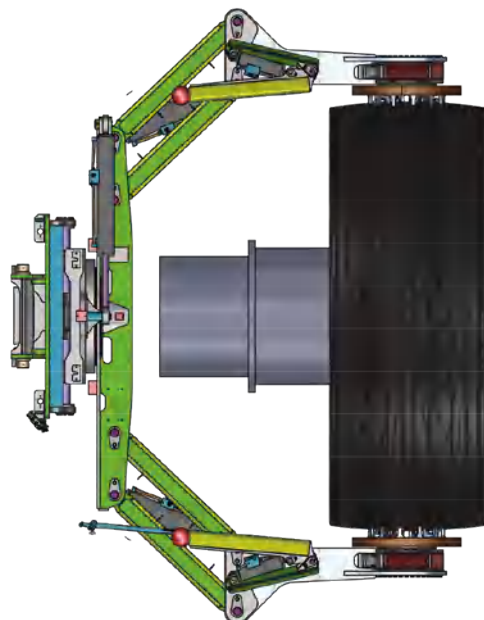
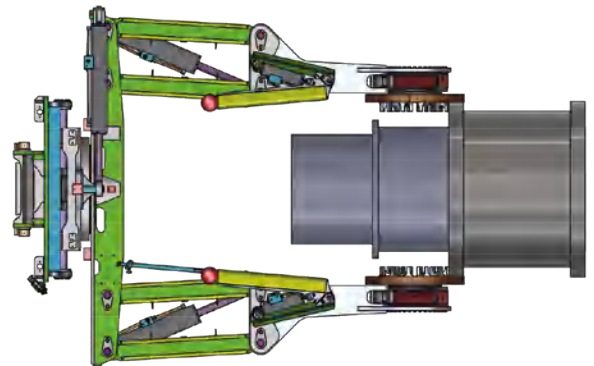
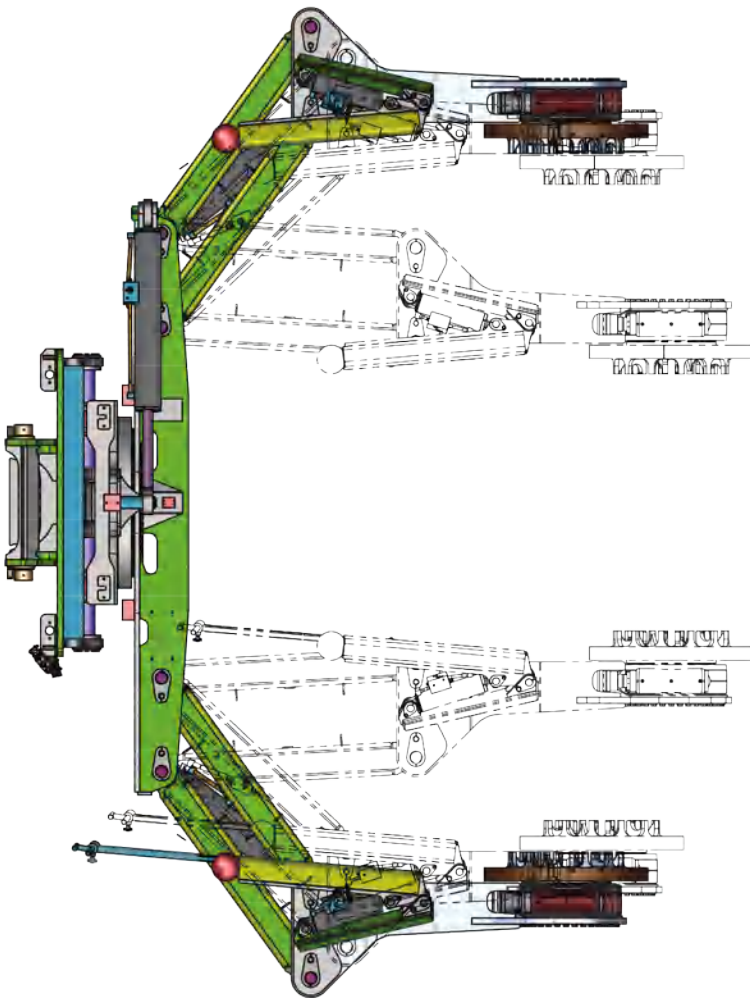

HANDLING PADS

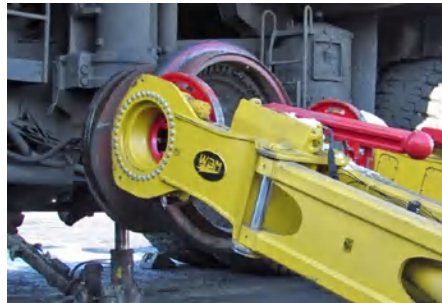

RIM COMPONENT HANDLING PADS

- Replaceable teeth
- Easily replaceable when worn or damaged, saving time and money.
- Operator can pick up heavy rim components with finger-tip control from the cab and position them on the hub/rim, reducing risk of damage or injury.

FALL ARREST ARMS



BEAD BREAKER FALL ARREST ARMS

- Dual function: bead break fall arrest safety arms protect the tire technician from any potential of the tire to fall on them when installing the first or last wheel nut. The bead breaker function allows the tire bead and/or flange ring (bead seat band) to be pushed back while holding the tire firmly on the outside, increasing safety and reducing manual labour required.
- Optional lock-ring catcher: positioned to safely catch the lock ring, stopping it from free-falling to the ground.

TM FUNCTION CONTROLS



SELECTOR SWITCH HANDLE

Connects to machine 3rd valve / lever to provide TM operation. (Standard T3 -T10).



JOYSTICK CONTROL

Dual axis, joystick control with roller switches. All functions fully proportional and trigger safety release on clamp open function. (Standard on T15W and above).

OPTIONAL PADDLE-STYLE CONTROL BOX

Special build to order only.

OPTIONAL CAMERA SYSTEMS

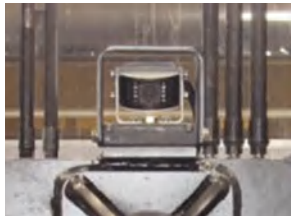

BASIC CAMERA

- 7" monitor



DUAL CAMERAS

- 7" monitor
- Standard 60 and 118 wide angle camera's allow greater range of view for the operator



ZOOM CAMERA

- 12" monitor
- 32x digital/ 30x optical zoom allows the operator to read tire serial number from the cab and install and align wheel studs and wheel without assistance, increasing safety and efficiency

LIGHTING



WORK LIGHTS

Two lights are included standard in the cross-arm on all models (except T3C and T5C).



OPTIONAL WORK LIGHTS

Additional two lights on elevated stands to provide increased visibility.

MAINTENANCE



CENTRAL LUBRICATION

Lincoln metering valve block with plastic grease lines to main hinge and hard to access grease points. Included as standard on T20W and above; optional on smaller models.



OPTIONAL AUTOMATIC PUMP & RESERVOIR

Guarded pump (12V or 24V) with 2L reservoir – adjustable grease intervals can be programmed to suit.

DIMENSIONS AND SPECIFICATIONS

TIRE MANIPULATOR - W SERIES MODELS - FLT - SPECIFICATIONS (IMPERIAL)										
DIMENSION	DESCRIPTION	T5W-35	T5W-R49	T10W-R51	T15W-R51	T20W-R57	T25W-R57	T30W-R63	T35W-R63	T40W-R63
FLT CLASS										
TARGET MACHINE		H155-180	H155-180	H330	H360	H400-450	H550-620HD	H550-650HD	H620-700HD	H700-800
RESIDUAL CAPACITY										
Ref PART #		176-401-0002	176-720-0000	176-905-0001	176-405-0000	176-410-000x	176-425-0000	176-705-0000	176-700-0006	176-735-0000
Base Assy		369-805-0016	369-805-0010	369-805-0014	369-805-0020	369-805-0029	369-805-0017	369-805-0024	369-805-0030	369-805-0023
Mount Assy		369-830-xxxx	369-830-xxxx	369-830-xxxx	369-830-xxxx	369-830-0013	369-830-0013	369-830-0033	369-830-0033	369-830-0038
TM MAX RATED CAPACITY (LB)		5,500	5,500	10,000	15,000	20,000	25,000	30,000	35,000	40,000
WEIGHT (LB)		3,300	3,575	6,015	7,600	12,550	15,200	18,450	21,300	21,315*
X2	C of G - HORIZONTAL	30	36	48	49.13	48.69	48.00	51.15 /58.44	50.75	48.31
Y2	C of G - VERTICAL	18	18	18	19.25	21.25	19.88	34.23	21.63	27.44*
A	MAX WIDTH (")	119.75	141.25	177.94	177.94	202.75	221.75	221.88	242.81	248.81
B1	CROSS ARM WIDTH	89.00	86.50	106.25	106.25	127.50	138.25	137.63	145.63	150.75
B2	SIDE SHIFT FRAME WIDTH	50.75	50.75	60.88	60.88	68.50	50.00	71.50	71.50	71.5
C	MOUNT OFFSET - INTEGRAL	12.00	14.46	14.13	13.56	18.82	18.19	15.50	15.25	17.13
D	THICKNESS	15.64	15.63	19.00	19.00	22.81	23.19	23.19	25.00	25.00
E1	MAX OPEN REACH	48.75	58.50	61.63	62.00	67.89	87.75	99.42	92.56	91.94
E2	MIN OPEN REACH	51.75	72.19	85.88	83.50	88.94	107.50	119.25	115.13	115.12
F	PAD DIAMETER	18.00	24.00	33.50	33.50	39.50	39.50	39.94	39.94	39.94
G	MAX REACH	60.68	84.19	102.63	100.25	108.68	130.00	142.47	135.75	135.4
H1	PAD THICKNESS	8.75	8.75	13.38	13.38	14.63	15.38	15.38	18.38	18.38
H2	ARM THICKNESS	15.50	15.58	20.88	20.90	21.34	28.50	28.38	35.75	35.75
O1	MIN CLOSED	19.50	30.00	18.00	18.00	40.00	32.00	32.00	34.00	40.00
O2	MAX OPEN	88.00	110.00	136.00	136.00	160.00	165.00	165.00	170.00	177.00
HYD CONTROL		SELECTOR SWITCH HANDLE	SELECTOR SWITCH HANDLE	SELECTOR SWITCH HANDLE	PROPORTIONAL JOYSTICK	PROPORTIONAL JOYSTICK	PROPORTIONAL JOYSTICK	PROPORTIONAL JOYSTICK	PROPORTIONAL JOYSTICK	PROPORTIONAL JOYSTICK
FUNCTIONS		4	4	4	5	5	5	5	5	5
PRESSURE (PSI)/ FLOW (GPM)		2500 @ 25-30	2500 @ 25-30	2500 @ 25-30	3000 @ 25-30	3000 @ 25-30	3000 @ 25-30	3000 @ 25-30	3000 @ 25-30	3000 @ 25-30
PAD ROTATION (Deg)		360	360	360	360	360	360	360	360	360
RIM HANDLER PADS		X	X	O	O	Y	Y	Y	Y	Y
BOLT ON TEETH		N	N	N	N	Y	Y	Y	Y	Y
BODY ROTATION (Deg)		90	90	90	90	90	90	90	90	90
SIDE SHIFT		8	8			16	16	16	16	16
FALL ARREST		MAN	MAN	MAN	HYD	HYD	HYD	HYD	HYD	HYD
BEAD BREAKER		X	X	X	X	Y	Y	Y	Y	Y
CENTRAL LUBE		O	O	O	O	Y	Y	Y	Y	Y
AUTO LUBE		O	O	O	O	O	O	O	O	O

